

# THLCDW

for 9"-21" LCD monitors  
with 100mm VESA patterns

**Must use 10mm screws on 20" model #s PDI-P20lcdc and LD-20A76UD**

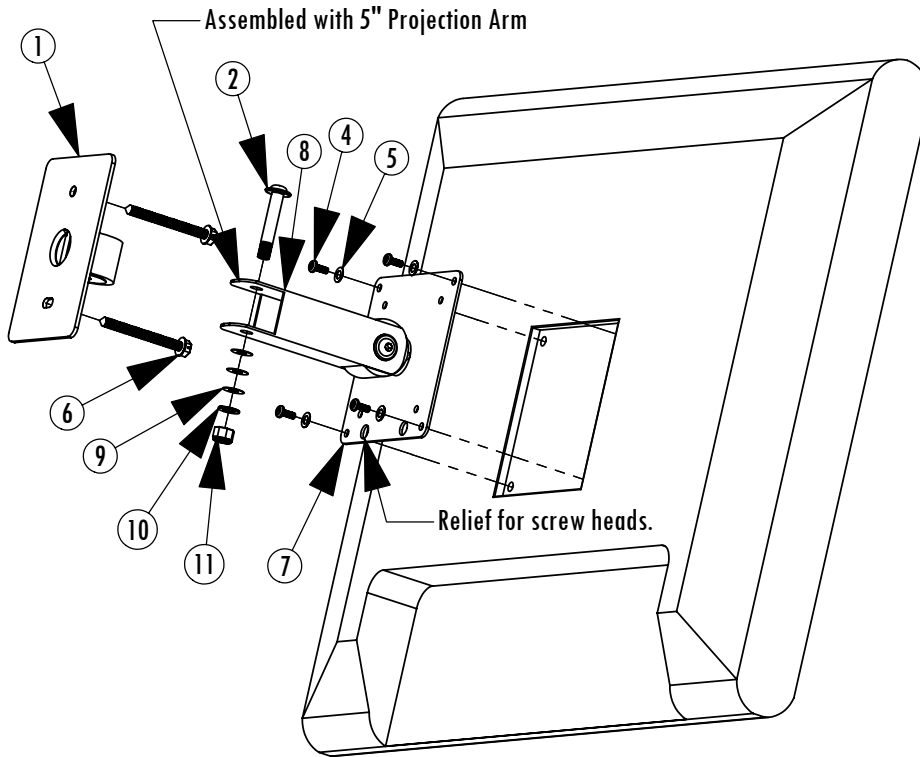

Remove flanged socket head cap screw (#2), washers (#9 & #10), and nylon nuts (#11) from LCD wall plate.

Attach LCD adapter (#7) to monitor with screws appropriate for your monitor. Use M4 x 10mm (#4) x .7P Screws and 5mm Flat Washers (#5) for model #s PDI-P20LCDC or LD-20A6UD.

M4 x 12mm x .7P (#3) are provided for Philips model monitors.

Predetermine the best possible viewing location for monitor and attach LCD wall plate to studs in wall with appropriate hardware. Lag screws (#6) have been provided for attachment to wood stud walls.

Attach LCD wall arm and monitor to LCD wall plate with hardware that was removed in step #1.

Check assembly for stability. Ensure all fittings and fasteners are properly tightened and safe.

**3**

4Pcs 4mm x 12mm Phillips Screws  
Caution! Do not use with model #s PDI-P20LCDC or LD-20A6UD

**WEIGHT 3 LBS**

**12**

3.00" Arm Included

ITEM NO.	DESCRIPTION	Qty.
1	LCD WALL PLATE W/ KNUCKLE	1
2	5/16-18 x 1-7/8" HMS FLANGED SOCKET HD CAP SCREWS	2
3	M4 x 12mm 0.7P MACHINE SCREWS	4
4	M4 x 10mm 0.7P MACHINE SCREWS	4
5	5mm Flat Washer	4
6	#14 x 2-1/2" LAG SCREWS	2
7	LCD ADAPTER PLATE W/ KNUCKLE	1
8	5" LCD WALL MOUNT ARM	1
9	5/16" BEVELLED WASHERS	6
10	5/16" FLAT WASHERS	2
11	5/16" NYLOCK NUTS	2
12	3.00" ARM INCLUDED	1